

## Datasheet

Part no. and prices: see pricelist



### **VITOPLEX 300** Type TX3A

Low temperature oil/gas boiler  
Three-pass boiler with multi layered convection heating surfaces  
For operation with a modulating boiler water temperature  
With a Vitotrans 300 as condensing unit

## Benefits at a glance

- Multi layered convection heating surfaces for high operational reliability and a long service life.
- Standard seasonal efficiency [to DIN] for operation with fuel oil/ natural gas:  
90 % (H<sub>s</sub>) [gross cv] / 96 % (H<sub>i</sub>) [net cv].
- Optional stainless steel flue gas/water heat exchanger enables use of condensing technology for higher standard seasonal efficiency [to DIN].
- Three-pass boiler with low combustion chamber loading, resulting in clean combustion with low emissions.
- Wide water galleries and large water content provide excellent natural circulation and reliable heat transfer.
- The integral Therm-Control start-up system replaces the shunt pump or constant return temperature raising facility, thereby saving installation time and costs.
- Fastfix installation system for rapid and simple installation
- With walk-on boiler cover – for easier installation and maintenance.
- Digital Vitotronic control system with communication capability ensures economical and reliable operation of the heating system. Standardised LON BUS for complete integration into building management systems.

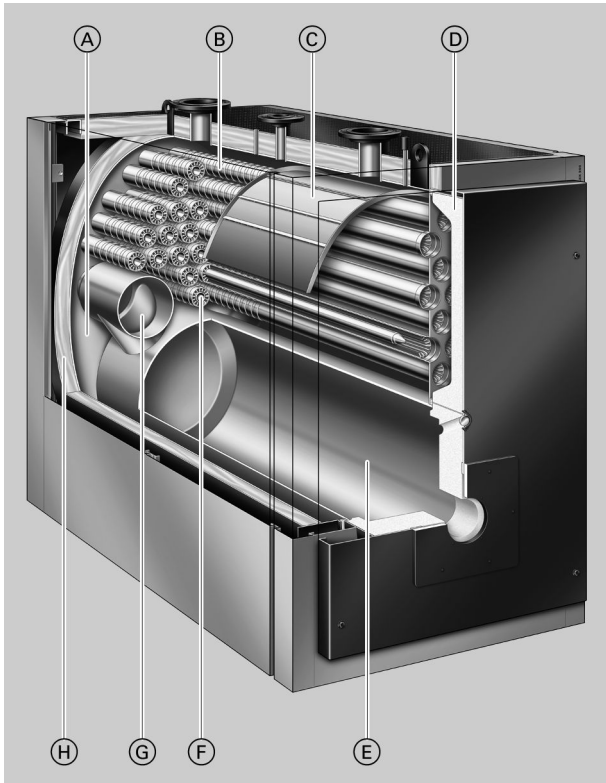

- (A) Wide water galleries and large water content ensure excellent natural circulation and easy hydraulic connection
- (B) Multi layered convection heating surfaces for high operational reliability and a long service life
- (C) Water deflector, prevents cold return water from directly impacting on the convection heating surfaces
- (D) Thermal insulation on boiler door
- (E) Combustion chamber – hot gas flue 1
- (F) Hot gas flue 3
- (G) Hot gas flue 2
- (H) Highly effective thermal insulation

## Boiler specification

### Specification

Rated heating output	kW	620	780	1000	1250	1600	2000
Rated heat input	kW	667	839	1075	1344	1720	2150
<b>CE designation</b> In accordance with the Gas Appliances Directive		CE-0085BT0478					
<b>Permiss. flow temperature</b> (= safety temperature)	°C	110 (to 120 °C on request)					
<b>Permiss. operating pressure</b>	bar kPa	6 600					
<b>Pressure drop on the hot gas side</b>	mbar Pa	3.5 350	4.0 400	4.0 400	5.0 500	8.5 850	8.0 800
<b>Boiler body dimensions</b>							
Length (dim. k) <sup>*1</sup>	mm	2230	2230	2480	2480	3100	3100
Width (dim. c)	mm	1085	1085	1180	1180	1280	1280
Height (incl. connectors) (dim. e)	mm	1670	1670	1900	1900	2120	2120
<b>Overall dimensions</b>							
Total length (dim. f)	mm	2320	2320	2570	2570	3220	3220
Total width							
– with control unit (dim. a)	mm	1460	1460	1555	1555	1660	1660
– without control unit (dim. b)	mm	1285	1285	1380	1380	1485	1485
Total height (incl. lifting eyes) (dim. h)	mm	1690	1690	1920	1920	2140	2140
Height of anti-vibration boiler supports (under load)	mm	37	37	37	37	37	37
<b>Foundation</b>							
Length	mm	1900	1900	2150	2150	2700	2700
Width	mm	1200	1200	1300	1300	1400	1400
<b>Combustion chamber diameter</b>	mm	620	620	720	720	720 <sup>*2</sup>	720 <sup>*2</sup>
<b>Combustion chamber length</b>	mm	1700	1700	1930	1930	2530	2530
<b>Weight boiler body</b>	kg	1650	1890	2560	2715	3545	4025
<b>Total weight</b> Boiler incl. thermal insulation and boiler control unit	kg	1750	1990	2705	2860	3725	4205
<b>Boiler water content</b>	litres	965	900	1510	1440	2475	2315
<b>Boiler connections</b>							
Boiler flow and return	PN 6 DN	100	100	125	125	150	150
Safety connection (safety valve)	PN 16 DN	50	50	65	65	65	65
Drain	R (external)	1¼	1¼	1¼	1¼	1¼	1¼
<b>Flue gas parameters <sup>*3</sup></b>							
Temperature (at boiler water temperature 60 °C)							
– at rated heating output	°C			160			
– at partial load	°C			105			
Temperature (at boiler water temperature 80 °C)	°C			175			
Flue gas mass flow rate							
– for natural gas	kg/h			1.5225 x combustion output in kW			
– for fuel oil EL	kg/h			1.5 x combustion output in kW			
Required draught	Pa/mbar	0	0	0	0	0	0
<b>Flue outlet</b>							
Nominal diameter	Ø mm	300	300	350	350	400	400
Outdoors	Ø mm	298	298	348	348	398	398
<b>Total gas capacity</b> Combustion chamber, hot gas flues, return pipes, diverter and flue gas collector	m <sup>3</sup>	0.80	0.80	1.25	1.25	1.90	2.00
<b>Standard seasonal efficiency [to DIN]</b> (for operation with fuel oil/natural gas) for heating system temperature 75/60 °C	%	90 (H <sub>s</sub> ) [gross cv] / 96 (H <sub>i</sub> ) [net cv]					
<b>Standby loss</b> q <sub>B,70</sub>	%	0.15	0.13	0.13	0.12	0.12	0.11
<b>Matching Vitotrans 300</b>							

\*1 Boiler door removed.

\*2 Conical combustion chamber 720/840 mm (combustion chamber diameter front/rear)

\*3 Values for calculating the size of the flue system to EN 13384, relative to 13.2 % CO<sub>2</sub> for fuel oil EL and 10 % CO<sub>2</sub> for natural gas.

Flue gas temperatures as actual gross values at 20 °C combustion air temperature.

The details for partial load refer to an output of 60 % of the rated heating output. If the partial load differs from that stated above (depending on operating mode), calculate the flue gas mass flow rate accordingly.

## Boiler specification (cont.)

Rated heating output	kW	620	780	1000	1250	1600	2000
– gas operation	Part no.	Z007 212		Z007 213		Z007 214	
– oil operation	Part no.	Z007 215		Z007 216		Z007 217	
<b>Rated heating output</b>							
Boiler with Vitotrans 300							
– gas operation	kW	682	858	1100	1375	1760	2200
– oil operation	kW	663	834	1070	1337	1715	2140
<b>CE designation</b>		CE-0085BT0479					
Vitotrans 300 in conjunction with boiler as a condensing unit							
<b>Pressure drop on the hot gas side</b>	mbar	3.9	4.6	5.0	6.4	9.5	9.75
Boiler with Vitotrans 300	Pa	390	460	500	640	950	975
<b>Total length</b>	mm	3770		3620		4430	
Boiler with Vitotrans 300 without burner							

## Dimensions

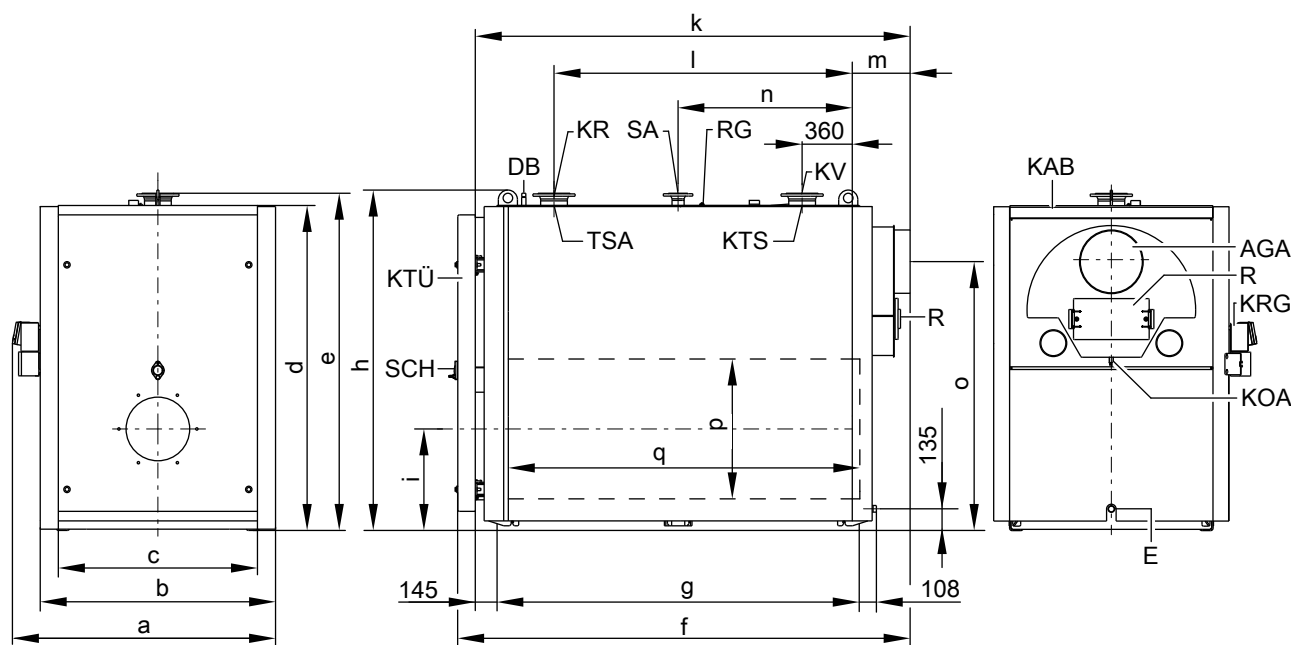

AGA	Flue outlet	KTÜ	Boiler door
DB	Female connection for maximum pressure limiter (R ½)	KV	Boiler flow
E	Drain	R	Cleaning aperture
KAB	Boiler cover (walk-on)	RG	Female connection for additional control equipment (R ½)
KOA	Condensate drain	SA	Safety connection (safety valve)
KR	Boiler return	SCH	Inspection port
KRG	Boiler control unit	TSA	Sensor well for Therm-Control temperature sensor
KTS	Boiler water temperature sensor (shown offset)		

### Dimensions

Rated heating output	kW	620	780	1000	1250	1600	2000
a	mm	1460	1460	1555	1555	1660	1660
b	mm	1285	1285	1380	1380	1485	1485
c	mm	1085	1085	1180	1180	1280	1280
d	mm	1590	1590	1815	1815	2035	2035
e	mm	1670	1670	1900	1900	2120	2120
f	mm	2320	2320	2570	2570	3220	3220
g (length of base rails)	mm	1775	1775	2005	2005	2610	2610
h	mm	1690	1690	1920	1920	2140	2140
i	mm	525	525	580	580	640	640
k (transport dimension)	mm	2230	2230	2480	2480	3100	3100
l	mm	1420	1420	1650	1650	2250	2250
m	mm	310	310	330	330	350	350
n	mm	890	890	1005	1005	1305	1305
o	mm	1270	1270	1480	1480	1690	1690

## Boiler specification (cont.)

Rated heating output	kW	620	780	1000	1250	1600	2000
p	∅ mm	620	620	720	720	720*2	720*2
q	mm	1700	2000	1930	2150	2530	2530

Dim. k: Boiler door removed.

## Siting

### Minimum clearances

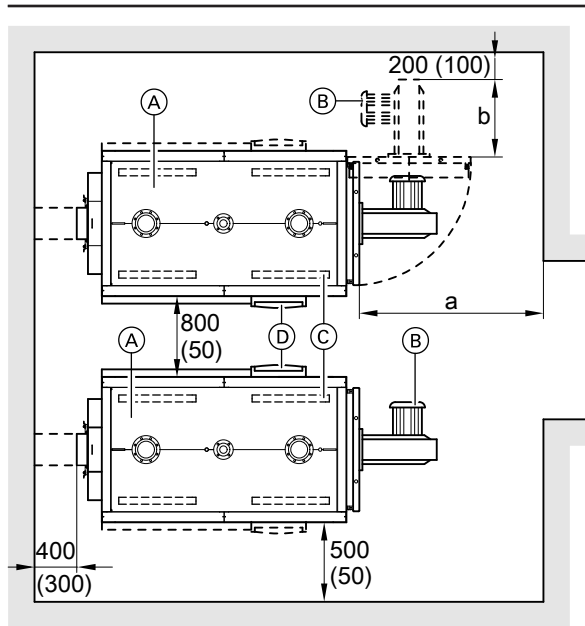

- (A) Boiler
- (B) Burner
- (C) Anti-vibration boiler supports
- (D) Boiler control unit

### Dimensions

Rated heating output	kW	620	780	1000	1250	1600	2000
a	mm	2000	2000	2400	2400	2900	2900
b	mm	Installed burner length					

To ensure easy installation and maintenance, observe the stated dimensions. Where space is tight, only the minimum clearances (dimensions in brackets) need to be maintained. In the delivered condition, the boiler door opens to the right. The hinge pins can be repositioned so the door swings open to the left.

Dim. a: Maintain this space in front of the boiler to enable the hot gas flues to be cleaned.

If the control units are fitted on opposite sides of the boilers, the 800 mm clearance between the individual boilers can be reduced to 50 mm.

### Siting conditions

- Prevent air contamination by halogenated hydrocarbons (e.g. as contained in sprays, paints, solvents and cleaning agents)
- Prevent very dusty conditions
- Prevent high levels of humidity
- Prevent frost and ensure good ventilation

Otherwise, the system may suffer faults and damage.

In rooms where air contamination through **halogenated hydrocarbons** may occur, install the boiler only if adequate measures can be taken to provide a supply of uncontaminated combustion air.

## Burner installation

Fit the burner plate included in the standard delivery on the hinged boiler door.

The burner must be fitted to the burner plate; mounting it directly onto the boiler door without a burner plate is not possible.

Drill the supplied burner plate on site, in accordance with the burner dimensions.

Burner plates may be factory fitted on request (chargeable option). If this is required, state the burner make and type when ordering.

The flame tube must protrude from the thermal insulation of the boiler door.

The burner must not exceed a total weight of 180 kg, otherwise supports will need to be provided on site.

## Boiler specification (cont.)

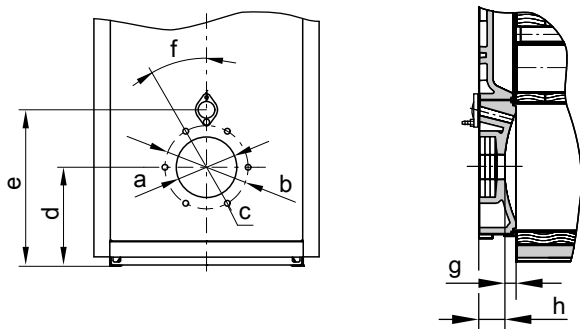

### Dimensions

Rated heating output	kW	620	780	1000	1250	1600	2000
a	∅mm	350	350	400	400	400	400
b	∅mm	400	400	490	490	490	490
c	Number/ thread	6/M12					
d	mm	525	525	580	580	640	640
e	mm	785	785	885	885	970	970
f	°	15	15	30	30	30	30
g	mm	75	75	75	75	75	75
h	mm	150	150	150	150	170	170

## Pressure drop on the heating water side

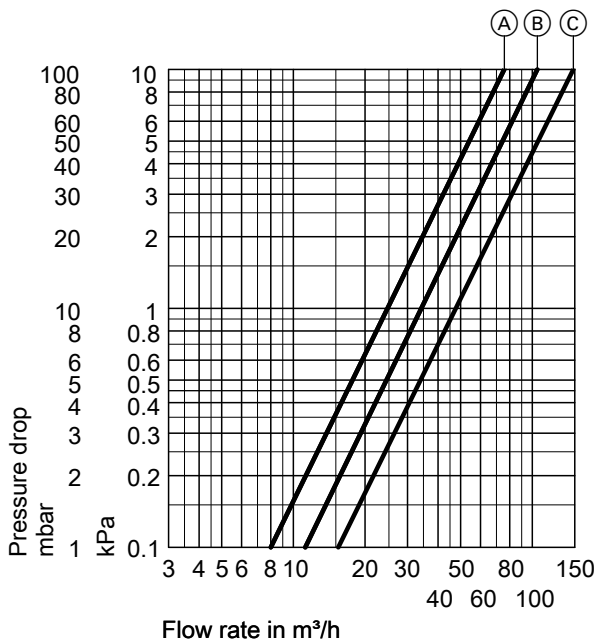

The Vitoplex 300 is only suitable for fully pumped hot water heating systems.

- (A) Rated heating output 620 and 780 kW
- (B) Rated heating output 1000 and 1250 kW
- (C) Rated heating output 1600 and 2000 kW

## Vitotrans 300 specification

### Specification

Vitotrans 300 – gas operation	Part no.	Z007 212	Z007 213	Z007 214
– oil operation	Part no.	Z007 215	Z007 216	Z007 217
<b>Rated boiler heating output</b>	kW	620-900	630-1300	1600-2000
<b>Rated heating output of the Vitotrans 300 for</b>				
– gas operation	from kW	62.0	63.0	160.0
	to kW	94.5	136.0	204.0
– oil operation	from kW	43.0	44.0	115.0
	to kW	64.0	93.0	140.0
<b>Permiss. operating pressure</b>	bar	6	6	6
	kPa	600	600	600
<b>Permiss. flow temperature</b> (= safety temperature)	°C	110 (120)	110 (120)	110 (120)
<b>Pressure drop on the hot gas side</b>	mbar	0.4-0.8	0.4-1.6	1.0-1.75
	Pa	40-80	40-160	100-175
<b>Flue gas mass flow rate</b>	from kg/h	1010	1057	2670
	to kg/h	1500	2160	3300
<b>Overall dimensions</b>				
Total length (dim. f)	mm	1046	1046	1200
Total width (dim. m), incl. mating flanges	mm	1097	1097	1226
Total height (dim. i)	mm	1783	1783	2024
<b>Transport dimensions</b>				
Length (dim. f)	mm	1046	1046	1200
Width (dim. m), excl. mating flanges	mm	989	989	1112
Height (dim. a)	mm	1674	1674	1915
<b>Total weight</b> heat exchanger incl. thermal insulation	kg	355	355	470
<b>Content</b>				
Heating water	litres	215	215	295
Flue gas	m <sup>3</sup>	0.336	0.336	0.544
<b>Connections</b>				
Heating water flow and return	PN 16 DN	100	100	125
Condensate drain	∅ mm	32	32	32
<b>Flue gas connection</b> *4	DN	300	300	350

#### Rated heating output range of the Vitotrans 300 and flue gas temperature

Heating output of the Vitotrans 300 with flue gas cooling of 200/65 °C during gas operation and 200/70 °C during oil operation, with a heating water temperature rise in the Vitotrans 300 from 40 °C to 42.5 °C.

For conversion to other temperatures, see chapter "Output data".

#### Pressure drop on the hot gas side

Pressure drop on the hot gas side at rated heating output. The burner must overcome the hot gas pressure drop of the boiler, the Vitotrans 300 and the flue pipe.

#### Tested quality

 CE designation according to current EC Directives at a permissible flow temperature (safety temperature) of up to 110 °C to EN 12828.

## Vitotrans 300 specification (cont.)

### Dimensions

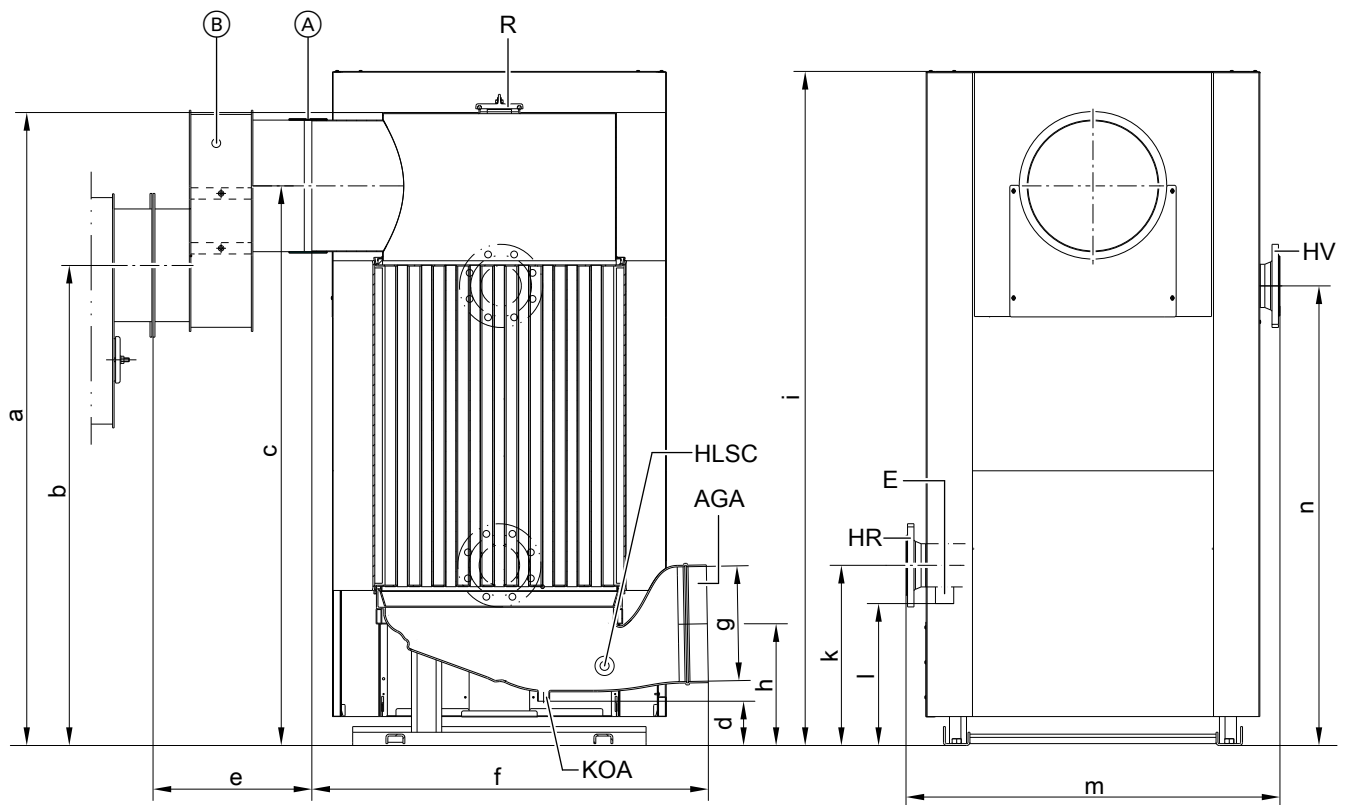

- (A) Connection collar  
 (B) Offset flue adaptor, only with Z007 212 and Z007 215 for Vitoplex boilers

- HR Heating water return (inlet)  
 HV Heating water flow (outlet)  
 KOA Condensate drain  
 R Cleaning aperture  
 STB Fem. connection for flue gas high limit safety cut-out

- AGA Flue outlet  
 E Drain connector

#### Dimensions

Part no.		Z007 212 Z007 215	Z007 213 Z007 216	Z007 214 Z007 217
a	mm	1674	1674	1825
b	mm	1270	1480	1690
c	mm	1480	1480	1690
d	mm	116	116	116
e	mm	420	15	15
f	mm	1046	1046	1200
g (internal)	∅ mm	301	301	352
h	mm	321	321	356
i	mm	1783	1783	1934
k	mm	476	476	580
l	mm	375	375	469
m	mm	989	989	1112
n	mm	1215	1215	1297

#### Note

The height of the Vitotrans 300 can be adjusted via levelling bolts on the base plate or height-adjustable base rails.

#### Delivered condition

Heat exchanger body with fitted flue gas header and integral feet.  
 Mating flanges and screws are fitted to the connector.

- 1 Crate with offset flue adaptor  
 1 Box with thermal insulation for offset flue adaptor

- 1 Box with thermal insulation for flue gas/water heat exchanger  
 1 Box with collar



## Vitotrans 300 specification (cont.)

### Pressure drop on the heating water side

Part no. Z007 212 to Z007 217

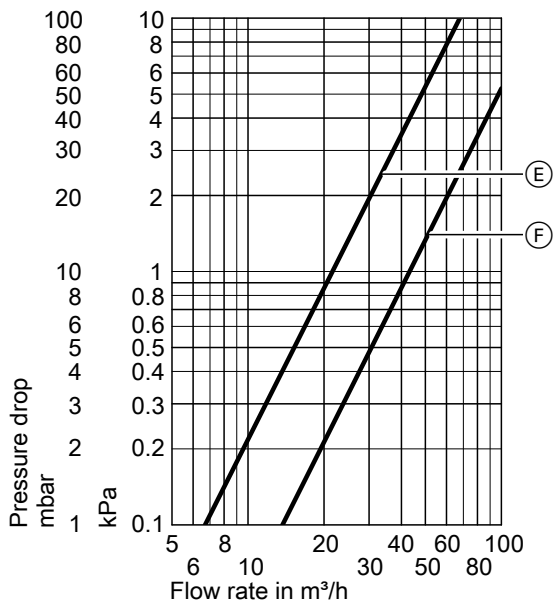

Part no.	Curve
Z007 212	Ⓔ
Z007 213	
Z007 215	
Z007 216	
Z007 214	
Z007 217	Ⓕ

### Output data

Vitotrans 300 for gas operation

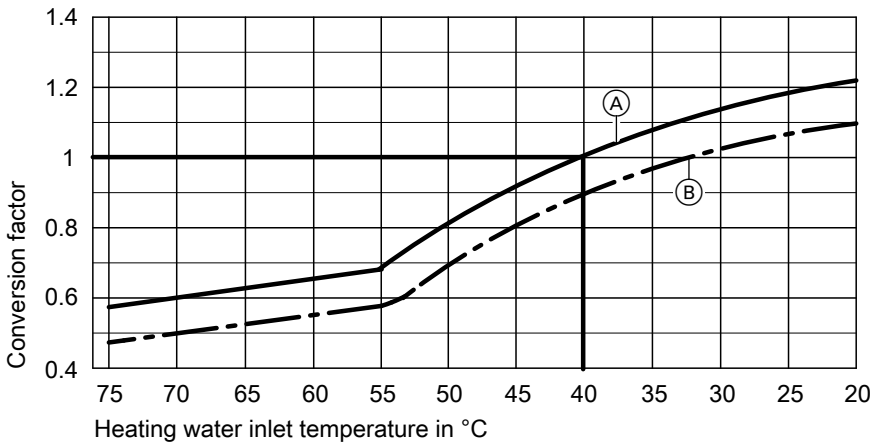

- Ⓐ Flue gas inlet temperature 200 °C  
 Ⓑ Flue gas inlet temperature 180 °C

#### Conversion of the output data

The heating output data of the Vitotrans 300 flue gas/water heat exchanger refers to a flue gas inlet temperature of 200 °C and a heating water inlet temperature into the heat exchanger of 40 °C.

For different conditions the heating output can be calculated by multiplying the specified rated heating output by the conversion factor established from the diagram.

### Boiler delivered condition

Boiler body with fitted boiler door, fitted cleaning cover and permanently fitted boiler cover.

Mating flanges are fitted to all connectors.

Adjusting screws and burner plate are supplied in the combustion chamber.

- 2 boxes with thermal insulation and 1 cleaning brush
- 1 product pack (coding card and technical documentation)
- 1 box with boiler control unit and 1 bag with technical documentation
- 1 Therm-Control

## Boiler delivered condition (cont.)

### Control unit versions

#### For single boiler systems:

- **Vitotronic 100** (type GC1B)  
Boiler control unit for constant boiler water temperature
- **Vitotronic 200** (type GW1B)  
Weather-compensated boiler control unit
- **Vitotronic 300** (type GW2B)  
Weather-compensated boiler and heating circuit control unit for up to 2 heating circuits with mixers
- **Vitotronic 200-H** (type HK1B or HK3B)  
Weather-compensated heating circuit control unit for 1 or up to 3 heating circuits with mixers
- **Vitocontrol control panel**

#### For multi boiler systems (up to 4 boilers):

- **Vitotronic 100** (type GC1B) and **LON module** with **Vitotronic 300-K** (type MW1B)  
For weather-compensated cascade control of up to 4 boilers and control of up to 2 heating circuits with mixers.  
(The first boiler is delivered with the standard control equipment for the multi boiler system.)
- **Vitotronic 100** (type GC1B) and **LON module** for every additional boiler in the multi boiler system
- **Vitotronic 200-H** and **LON module** (type HK1B or HK3B) for 1 or up to 3 heating circuits with mixers
- **Vitocontrol control panel**

## Boiler accessories

See pricelist and "Boiler accessories" datasheet.

## Operating conditions with Vitotronic boiler control units and Therm-Control

For water quality requirements, see the technical guide to this boiler.

Operation with burner load		Requirements	
		≥ 60 %	< 60 %
1.	Heating water flow rate	None	
2.	Boiler return temperature (minimum value)*5	None*6	
3.	Lower boiler water temperature	– Oil operation 40 °C – Gas operation 50 °C	– Oil operation 50 °C – Gas operation 60 °C
4.	Two-stage burner operation	Stage 1: 60 % of rated heating output	No minimum load required
5.	Modulating burner operation	Between 60 and 100 % of rated heating output	No minimum load required
6.	Reduced mode	If no heat is required, the boiler can be shut down.	
7.	Weekend setback	As per reduced mode	

## Operating conditions with Vitotronic boiler control unit without Therm-Control

For water quality requirements, see the technical guide to this boiler.

Operation with burner load		Requirements		
		< 40 %	> 40 % < 60 %	> 60 %
1.	Heating water flow rate	None		
2.	Boiler return temperature (minimum value)	– Oil operation 50 °C – Gas operation 60 °C	– Oil operation 45 °C – Gas operation 55 °C	None
3.	Lower boiler water temperature	– Oil operation 55 °C – Gas operation 65 °C	– Oil operation 50 °C – Gas operation 60 °C	– Oil operation 40 °C – Gas operation 50 °C
4.	Two-stage burner operation	No minimum load required		Stage 1: 60 % of rated heating output
5.	Modulating burner operation	No minimum load required		Between 60 and 100 % of rated heating output
6.	Reduced mode	If no heat is required, the boiler can be shut down.		
7.	Weekend setback	As per reduced mode		

## Design/engineering information

### Mounting a suitable burner

Delivery without burner

\*5 A suitable system example for installation of a return temperature raising facility can be found in the system examples technical guide.

\*6 No requirements; only in conjunction with Therm-Control.

## Design/engineering information (cont.)

Suitable pressure-jet oil/gas burners are available from Weishaupt or ELCO and should be ordered separately (see pricelist). Delivery direct from Weishaupt or ELCO.

The material of the burner head must be suitable for operating temperatures of at least 500 °C.

### Pressure-jet oil burner

The burner must be tested and designated to EN 267.

### Pressure-jet gas burner

The burner must be tested to EN 676 and CE-designated in accordance with Directive 2009/142/EC.

### Burner adjustment

Adjust the oil or gas throughput of the burner to suit the rated boiler heating output.

## Permissible flow temperatures

Hot water boiler for permissible flow temperatures (= safety temperatures)

### ■ Up to 110 °C

#### CE designation:

CE-0085 in compliance with the Gas Appliances Directive

### ■ Above 110 °C (up to 120 °C) (with individual test certification on request)

#### CE designation:

CE-0035 in compliance with the Pressure Equipment Directive

For operation with safety temperatures in excess of 110 °C additional safety equipment is required.

– Boilers with a safety temperature **above 110 °C** must be supervised in accordance with the Health & Safety at Work Act [Germany]. In accordance with conformity assessment diagram no. 5 of the EU Pressure Equipment Directive, these boilers must be classed as category IV.

The system must be tested prior to its 1st commissioning.

– Annually – external inspection, inspection of the safety equipment and water quality

– Every 3 years – internal inspection (alternatively carry out a water pressure test)

– Every 9 years – water pressure test (for max. test pressure, see the type plate)

An approved inspection body (e.g. TÜV [in Germany]) must carry out the test.

## For further information on design/engineering

See the technical guide to this boiler.

## Tested quality

 CE designation according to current EC directives.

Subject to technical modifications.

Viessmann Werke GmbH & Co. KG  
D-35107 Allendorf  
Telephone: +49 6452 70-0  
Fax: +49 6452 70-2780  
[www.viessmann.com](http://www.viessmann.com)

Viessmann Limited  
Hortonwood 30, Telford  
Shropshire, TF1 7YP, GB  
Telephone: +44 1952 675000  
Fax: +44 1952 675040  
E-mail: [info-uk@viessmann.com](mailto:info-uk@viessmann.com)

5414 661 GB